

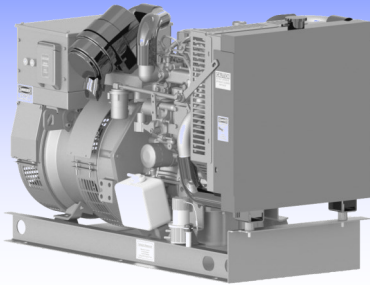

“CD” SERIES - CD10



**PURPOSE BUILT FOR:
PRIME POWER, INDUSTRIAL, MOBILE EQUIPMENT
MOTOR VEHICLES, CRITICAL APU's**

MODEL CD10 - 10.0kW

SPECIFICATIONS

Robust AC Power Source

DUTY RATING: Industrial, Continuous

SIZE: 40.34”L x 18.61”Wx 26.94”H

WEIGHT: 605 Lbs.

OUTPUT CURRENT:

240/120VAC, 1 Phase, 60 Hz

240VAC, 3 Phase, 60 Hz

480VAC, 3 Phase, 60 Hz

208VAC, 3 Phase, 60 Hz

POWER RATING:

10.0 kW Intermittent

9.0 kW Continuous

ENGINE:

3 Cylinder Diesel

Liquid Cooled, 1800RPM

ENGINE SOUND LEVEL:

80 dB(A) @ 1 Meter

65 dB(A) @ 7 Meters

A.C. ALTERNATOR TYPE:

4-Pole, Electronic Regulated, 1800 RPM,

60Hz, Insulation Class “H”

FEATURES & BENEFITS

- *A factory engineered, proven, built and production tested power system by Stadco® a division of Stauffer Diesel Inc. Independent AC power source*
- *Suitable for either free-standing or compartment duty. Modular design - easier installation.*
- *Each generator is designed to pass NFPA 2 Hour load test at continuous load*
- *Designed for Prime Power, Mobile Equipment, Motor Vehicles, Critical APU's*
- *Robust High Density, Welded Aluminum Heat Exchanger*
- *Stands up to the heat. Wide operating temperature range: 0°F to 122°F. (50°C)*
- *Easy Access to all routine Service Points*
- *Convenient connections to vehicle battery and diesel fuel tank*
- *Powered with Mitsubishi Diesel 1800RPM Engine*
- *EPA Emissions Compliant with no exhaust after-treatment required.*
- *Safety Protection System continually monitors Engine Condition. Virtually eliminates catastrophic failures.*
- *Standard Digital Control System - Common Controller*
- *4 Pole brushless alternator for extended service life*
- *Muffler Exhaust Kit included - Shipped Loose.*
- *Supported by a 2-Year or 2000 Hr. Limited Warranty and Money Back Guarantee see Stadco® policy #D25.*

©2013 STADCO® PRODUCTS DIVISION

PO BOX 586 • 34 STAUFFER LANE • EPHRATA, PA 17522

PHONE: (717)738-2500 • FAX: (717)738-2550

EMAIL: gensales@staufferdiesel.com • Website: www.stadcogen.com

STANDARD DIGITAL CONTROL SYSTEM - #1779



- Programmable Digital Control System (Remote mounted)
- Available with standard enclosure or optional flat panel
- Includes 10' Plug in cord w/weather-proof quick connectors.
- Metering for AC and DC electrical systems.
- Auto-crank and Preheat Capability are standard
- Automatic shutdowns and warnings.
- Auto-shutdown when power is fed from separate source.
- Refer to Bulletin #S160.13

OPTIONAL ACCESSORIES

- Remote Start/Stop Panel - Kit #1780 (in cab).
- Flat Panel Control System - Kit #1791
- Digital Control System w/AC Metering - Kit #1790.
- 12V Engine Preheat System - Installed
- Battery Box for BCI Group 27/31 (Shipped Loose)
- Second 12V Heater Plug for Intake Manifold (Alaska)
- 10 Ft. Extension Cord for Control Panel - Kit #1801.
- 20 Ft. Extension Cord for Control Panel - Kit #1802.
- Uprated Starter Motor 12V 3kW. (Alaska)
- Engine Heater, 120V, 300W Immersion Heater Mtd in Oil Pan, Plug into Shore Power. (Alaska)
- Silicone Engine Mounts. (Alaska)
- Exhaust Muffler Kit #1737 w/S.S. Flex Tubing (CD20 and CD30 Only)

STADCO SUPPORT SERVICES

- Toll free Stadco Tech service hotline: 1-800-377-2120
- Maintenance and service support information posted on Stadco website.
- Routine service provided by selling dealer or Stadco.
- Stadco services: shop and on-site road service. Plus comprehensive rebuilding services.

GENERAL DIMENSIONS

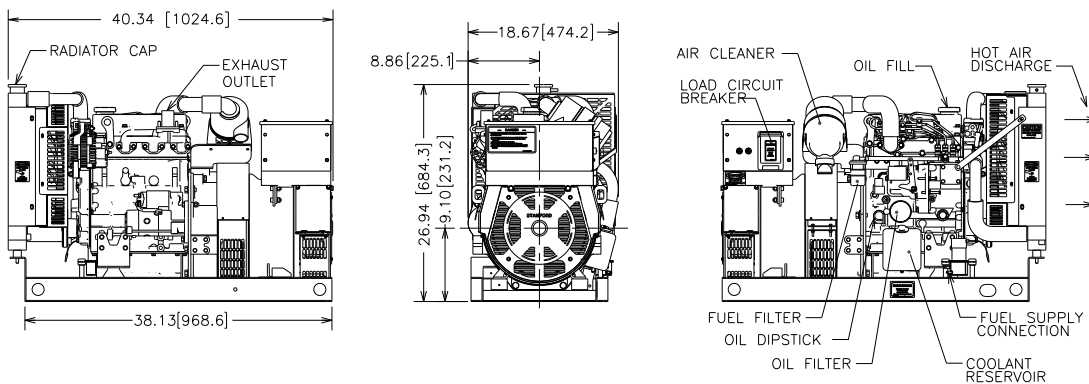

CD Series Generators available in sizes ranging from 10.0kW to 40.0kW

For Complete Specifications See Bulletin #S153.13

©2013 STADCO® PRODUCTS DIVISION

PO BOX 586 • 34 STAUFFER LANE • EPHRATA, PA 17522

PHONE: (717)738-2500 • FAX: (717)738-2550

EMAIL: gensales@staufferdiesel.com • Website: www.stadcogen.com