

PowerTech[®]
4045TFM Marine Engine
 Specifications

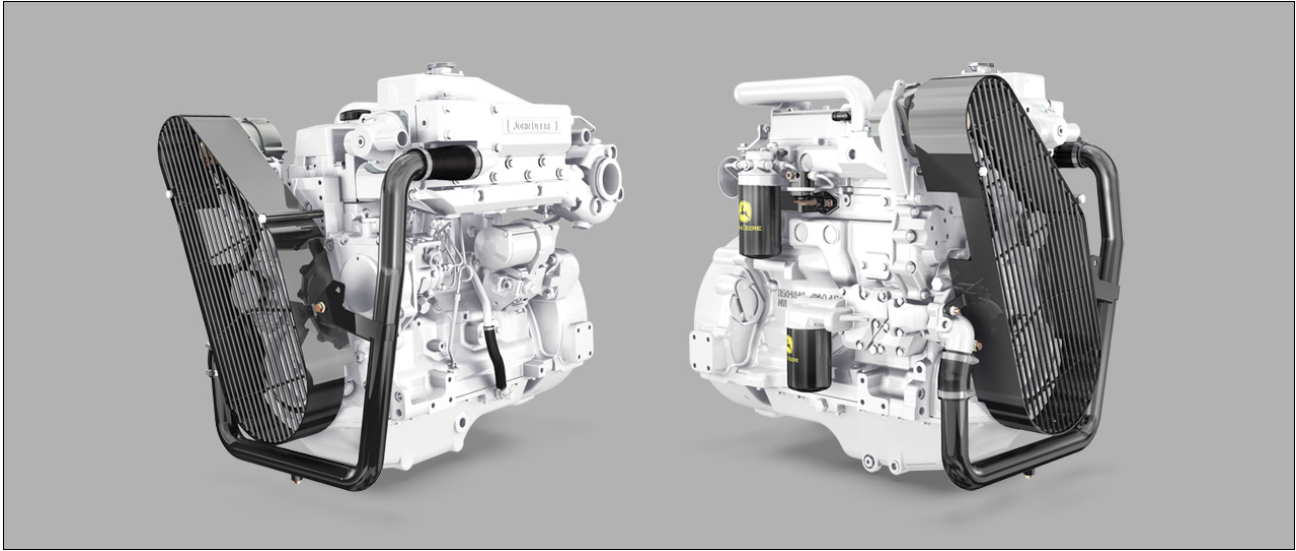

US EPA Marine Tier II Compliant
 IMO Exempt

PERFORMANCE DATA

	M3	M2	M1
Rated Power--hp (kW)	135 (101)	121 (90)	107 (80)
Rated Speed--rpm	2600	2500	2400
Low Idle Speed--rpm	650	650	650
Peak Torque--lb-ft (N.m)	352 (477)	330 (448)	310 (420)
Peak Torque Speed--rpm	1800	1700	1600
Fuel Consumption - gal/hr (L/h)			
2600	7.77 (29.4)	N/A	N/A
2400	6.23 (23.6)	6.18 (23.4)	5.84 (22.1)
2200	4.6 (17.4)	4.73 (17.9)	4.62 (17.5)
2000	3.46 (13.1)	3.46 (13.1)	3.46 (13.1)
1800	2.54 (9.6)	2.54 (9.6)	2.54 (9.6)
1600	1.77 (6.7)	1.77 (6.7)	1.77 (6.7)
1400	1.19 (4.5)	1.19 (4.5)	1.19 (4.5)
1200	0.74 (2.8)	0.74 (2.8)	0.74 (2.8)
1000	0.42 (1.6)	0.42 (1.6)	0.42 (1.6)

Photographs may show non-standard equipment

DIMENSIONS

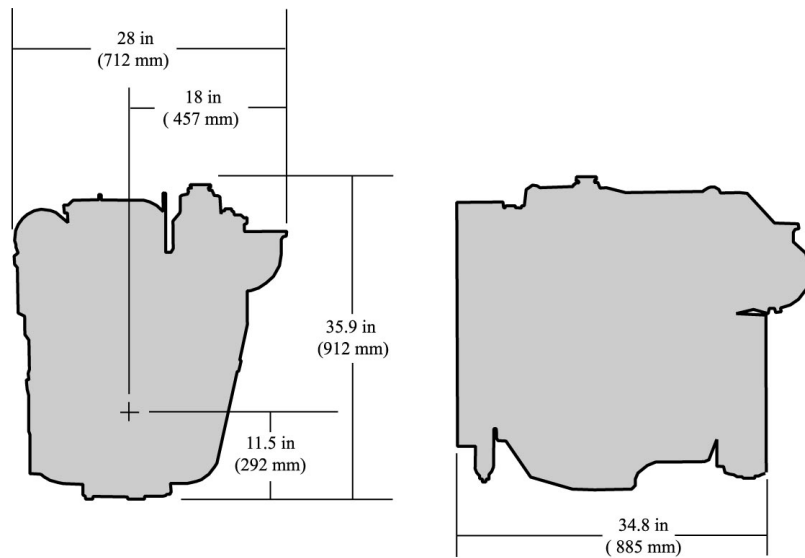

Propulsion & Auxiliary Power

GENERAL DATA

Model	4045TFM75	Length--in. (mm)	34.8 (885)
Number of Cylinders	4	Width--in. (mm)	28.0 (712)
Displacement- cu. in (L)	276 (4.5)	Height--in. (mm)	35.9 (912)
Bore and Stroke--in. (mm)	4.19 x 5.00 (106 x 127)	Weight, dry--lb (kg)	1018 (462)
Compression Ratio	17.6:1	Maximum Installed Angle	
Engine Type	In-line, 4-Cycle	Front Up--degrees	15
Aspiration	Turbo	Front Down--degrees	0
Aftercooling System	none		

FEATURES AND BENEFITS

Watercooled Turbocharger and Exhaust Manifold

- Cooler and quieter environment for vessel and crew
- Reduced external connections eliminates hoses and fittings that can leak or break

Replaceable wet-type cylinder liners

- Excellent heat dissipation
- Hardened and precision machined for long life
- Rebuild to original specifications

Internal Balancers

- Low noise and vibration for crew comfort

Corrosion Resistant Components

- Provides engine protection from the effects of seawater

Either-side Service

- Oil fill and dipstick combinations
- Remote oil filter for easier service access
- Application and service flexibility to provide installation convenience plus fast and easy maintenance

Heat exchanger or Keel Cooled

- High-capacity heat exchanger designed for reliable operation in adverse conditions
- Integrated expansion tank, heat exchanger and exhaust manifold reduce chances of leaks
- Keel cooler or heat exchanger options provide application flexibility

High torque and low rated rpm

- Enables the engine to turn larger propellers at lower speed for best efficiency
- Excellent vessel control and maneuvering
- Lower rated rpm limits vibration and noise for better crew comfort

Fuel System

- Electronically controlled rotary fuel injection pump with variable timing resulting in excellent fuel economy and excellent performance
- Self diagnostics and protection
- Electronic instrument panel with plain text messaging

Emissions

- US EPA Marine Tier II Compliant
- IMO Exempt

*Data based on keel cooled engine.
All values at rated speed and power with standard options unless otherwise noted.
Specifications and design subject to change without notice.*

M1 PERFORMANCE CURVE

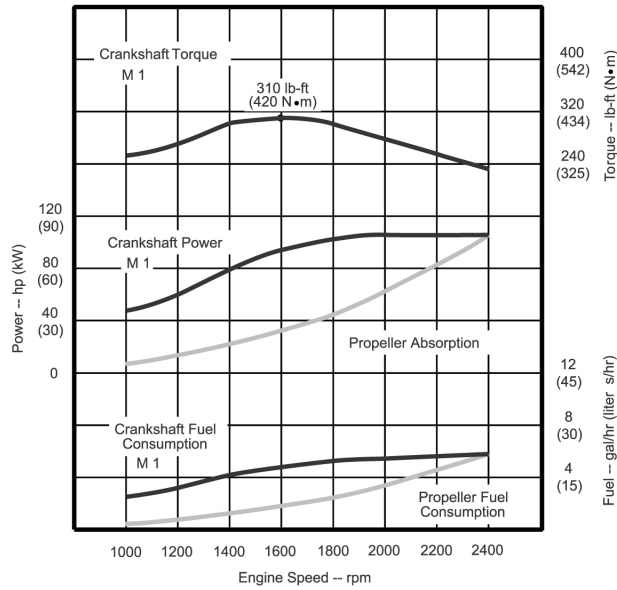

M2 PERFORMANCE CURVE

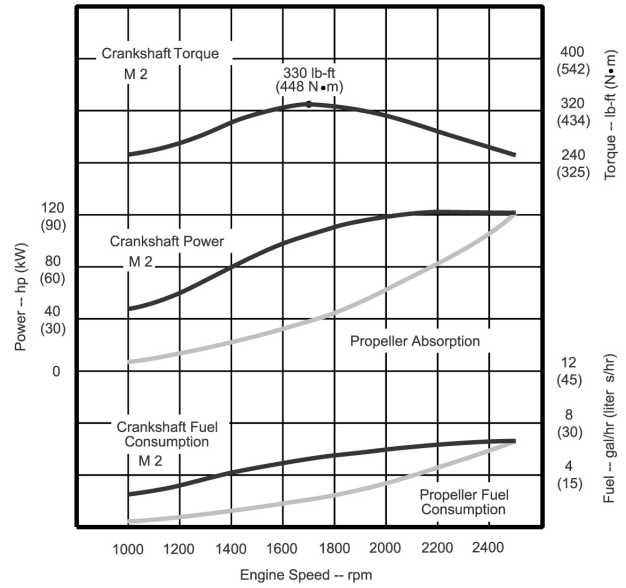

M3 PERFORMANCE CURVE

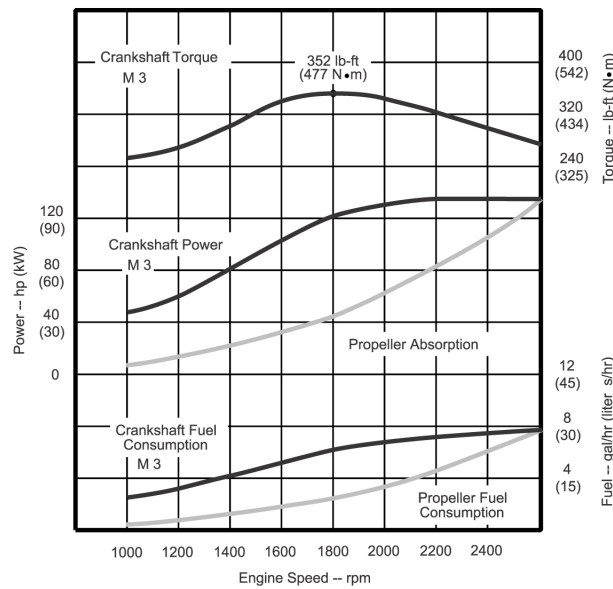

PERFORMANCE CURVE DEFINITIONS

Marine M1

For propulsion applications that may operate up to 24 hours a day at uninterrupted full power. These applications typically operate over 3,000 hours/year. M1 rating is ISO8665 "standard power" rating and the SAE J1228 "crankshaft power" rating.

Marine M2

For propulsion applications that may utilize full power up to 16 out of each 24 hours of operation. These applications typically operate at full power up to 65 percent of the time and accumulate as many as 3,000 hours/year.

Marine M3

For propulsion applications that may utilize full power no more than 4 out of each 12 hours of operation. These applications typically operate at full power up to 35 percent of the time and accumulate as many as 2,000 hours/year.

Marine M4

For propulsion applications that may utilize full power up to 1 out of each 12 hours of operation. These applications typically operate at full power up to 15 percent of the time and accumulate as many as 800 hours/year.

PowerTech
4045TFM Diesel Engine
 Specifications

Generator Set Applications

PERFORMANCE CURVE

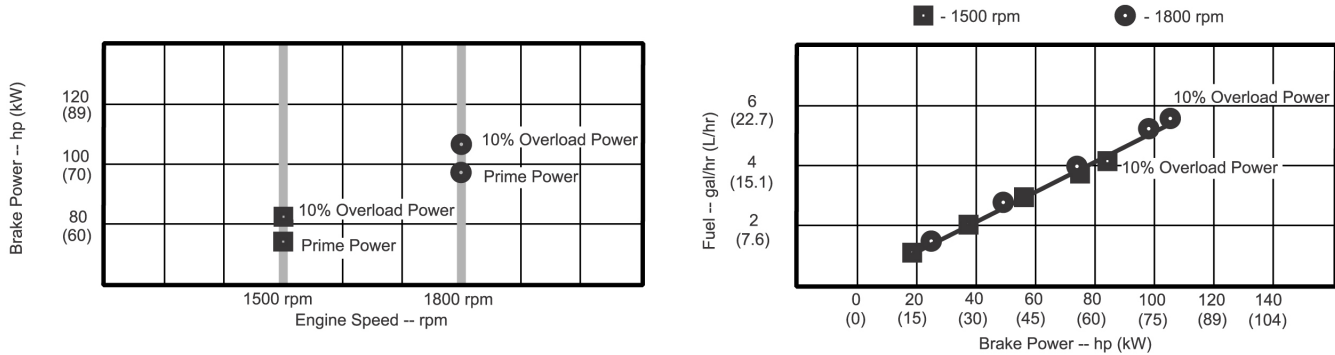

SYSTEM DATA

	1800 rpm	1500 rpm
Air System		
Engine Air Flow--ft ³ /min (m ³ /min)	184 (5.2)	124 (3.5)
Exhaust System		
Dry--in. (mm)	2.6 (65.0)	2.0 (50.0)
Wet--in. (mm)	3.0 (75.0)	2.6 (65.0)
Cooling System		
Coolant Flow--gal/min(L/min)	25 (94)	14 (53)
Sea Water System		
Pump Flow--gal/min(L/min)	22 (84)	18 (70)
Fuel System		
Governor Type	Electronic	Electronic
Governor Regulation--%	0-5	0-6
Total Fuel Flow--gal/hr (L/hr)	30.0 (113)	29.0 (109)

PERFORMANCE DATA

	1800 rpm	1500 rpm
10% Overload Engine Power--hp (kW)	107 (80)	82 (61)
Prime Engine Power--hp (kW)	98 (73)	74 (55)
Low Idle Speed--rpm	1150	1150
BMEP--psi (kPa)	155 (1071)	142 (980)

*Data based on keel cooled engine.
 All values at rated speed and power with standard options unless otherwise noted.
 Specifications and design subject to change without notice.*



John Deere Power Systems
 3801 W. Ridgeway Ave.
 PO Box 5100
 Waterloo, IA 50704-5100
 Phone 800-533-6446
 Fax 319-292-5075

John Deere Power Systems
 Usine de Saran
 La Foulonnerie - B.P. 11013
 45401 Fleury-les-Aubrais Cedex-France
 Phone (33) 2 38 82 61 19
 Fax (33) 2 38 82 60 00